

# LEGAL NOTICE

The **Town of Ridgefield** invites all interested parties to submit sealed bids on the following:

**BID DUE DATE:** May 14, 2026

**BID DUE TIME:** 11:00 am EST

**BID ITEM:** Ridgefield Golf Course Barrier Netting

**BID NUMBER:** 26-12

Terms and conditions as well as the description of items being bid are stated in the specifications. **Specifications may be obtained at the following address:**

**Town of Ridgefield  
David McFate  
400 Main Street  
Ridgefield, CT. 06877  
(203) 431-2720**

The return bid envelope must be marked and addressed to the following:

**TOWN OF RIDGEFIELD  
PURCHASING AND FINANCE  
MANAGER BID NUMBER: 26-12  
400 MAIN STREET  
RIDGEFIELD, CT. 06877**

Bids may be submitted via email to the following:

**[purchasing@ridgefieldct.gov](mailto:purchasing@ridgefieldct.gov)  
SUBJECT: 26-12(Company Name) Bid Package**

Bids must be received no later than the date and time stated above at the Purchasing Director's office on the second floor or via email. **For further information, please call David McFate at (203) 431-2720 or email at [purchasing@ridgefieldct.gov](mailto:purchasing@ridgefieldct.gov)**

**Results may be viewed at [https://www.ridgefieldct.gov/departments/purchasing/bid\\_notices.php](https://www.ridgefieldct.gov/departments/purchasing/bid_notices.php) after the bid opening.**

TOWN OF RIDGEFIELD  
REQUEST FOR BIDS (RFB)

Ridgefield Golf Course Barrier Netting

Issue Date: April 30, 2026  
RFP Number: 26-12

Proposal Due Date: Thursday, May 14, 2026 at 11:00 AM

1. INTRODUCTION

The Town of Ridgefield and Ridgefield Golf Course ("RGC") are soliciting proposals from qualified firms to replace existing protective netting along the RGC driving range located at 545 Ridgebury Road, Ridgefield, Connecticut 06877.

2. SCOPE

The Contractor shall provide all labor, supervision, equipment, and materials necessary to remove existing boundary netting and furnish and install new golf course barrier netting along the north boundary of Ridgefield Golf Club, in accordance with the requirements outlined below and with attached specifications and design drawings.

- Existing Netting Removal

Carefully remove all existing boundary netting located along the north boundary of the golf course (right side when facing downhill).

Removal shall include detachment from all cables, poles, and hardware.

Contractor shall take care to avoid damage to existing poles, cables, and hardware designated for reuse.

All removed netting materials shall be properly disposed of off-site, or turned over to the Owner if requested.

- Reuse of Existing Infrastructure

Existing poles, support cables, and associated hardware shall be reused.

Contractor shall inspect all existing components for structural integrity and suitability, and notify the Owner of any damaged or deficient components prior to installation.

Minor adjustments, tightening, or re-securing required for proper installation shall be included in the base scope.

- New Boundary Netting Installation

Furnish and install seven (7) new boundary net panels, in accordance with project drawings.

Netting shall match the existing height of current boundary netting.

Netting shall be properly tensioned and secured to existing poles and cable system.

Installation shall ensure uniform alignment and appearance, proper load distribution, and safe and durable attachment methods suitable for long-term outdoor exposure

- Material Specifications

Material shall be twisted-knotted nylon netting.

- #18 X 1" (191 l./twine) DuPont® Type 66-728 Twisted-Knotted Nylon Netting,

- Black Colored/Tarred Netting, UV Stabilized, Diamond Mesh 1.9mm Twine

- Twine Thickness: #18 (1.9mm diameter)

- Mesh Size: 1" square measurement (Diamond Mesh)

- Tensile Rating (single twine breaking strength): 191 lbs.

- Material & Construction: DuPont Type 66-728 Knotted Nylon, 3-Strand Twisted Twine, 100% Made-in-USA

- Finishing: Asphalt Tar Coated (UV/weather coating), Black Color

- Weight: 0.031 lb./square foot

- This netting is to be prepared with the diamond mesh pattern, and has a 5/16"

Braided polyester rope (3,200.lb/test) bordering. The bordering is installed around the perimeter edge meshes. Also, include a Central Rib-Line. Which is a Horizontal Wind-Line, placed horizontally in the vertical center of each net, to help protect from sudden wind gusts. DuPont 66-728 nylon netting features high tensile strengths and high abrasion resistance. This nylon netting is completely asphalt tar-coated for maximum UV and moisture durability.

### 3. OPTIONAL WORK – BALL-STOP INSTALLATION (ADD ALTERNATE)

Provide a separate, itemized quotation for the following optional work:

- Installation of a 350-foot-long ball-stop system, as indicated in project drawings.
- Scope to include:
  - All necessary materials, labor, and equipment
  - Any additional poles, foundations, or structural supports (if required)
  - Netting consistent in quality and specification with the boundary netting unless otherwise specified

### 4. PROTECTION OF PROPERTY

Contractor shall take all necessary precautions to protect existing golf course features, landscaping, and infrastructure, and to prevent damage to reused poles and hardware. Any damage caused by Contractor operations shall be repaired at no additional cost to the Owner.

## 5. SITE ACCESS AND COORDINATION

Work shall be coordinated with RGC management to minimize disruption to operations. Contractor shall maintain a clean and safe work area Contractor shall remove debris daily or as directed. Work hours and access restrictions shall be coordinated in advance.

## 6. SAFETY REQUIREMENTS

Contractor shall comply with all applicable federal, state, and local safety regulations. Proper safety measures shall be implemented, including use of personal protective equipment (PPE), securing work zones, and safe handling of elevated work and tensioned cables

## 7. COMPLETION REQUIREMENTS

Work shall be completed not later than May 24, 2026. Upon completion, Contractor shall:

- Ensure all netting is properly installed, tensioned, and secure
- Remove all debris and equipment from the site
- Conduct a final walkthrough with the Owner (if requested)

## 8. AVAILABILITY OF FUNDS

This project is contingent upon approval of associated capital expenditures. The Town of Ridgefield reserves the right to delay or cancel this project if funding is not approved.



# RIDGEFIELD Golf Course

545 Ridgebury Road Ridgefield, Connecticut

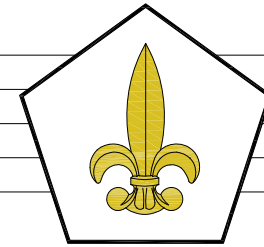

## Replacement of Golf Netting Project

August 7, 2025

Frank A. Sergiovanni, Director

> DO NOT SCALE DRAWING. NOT TO SCALE <

RIDGEFIELD GOLF COURSE

545 Ridgebury Road  
Ridgefield, Connecticut 06877

Replacement of Golf Netting Project

Submitted to DOB for Review  
Submitted as Conformed  
Approved for Construction

Client Comments

**RGC-01**



**NOTE:**

*If selected by the Owner,  
The Ball-Stop will be installed the entire length,  
from Pole 1 to Pole 8*

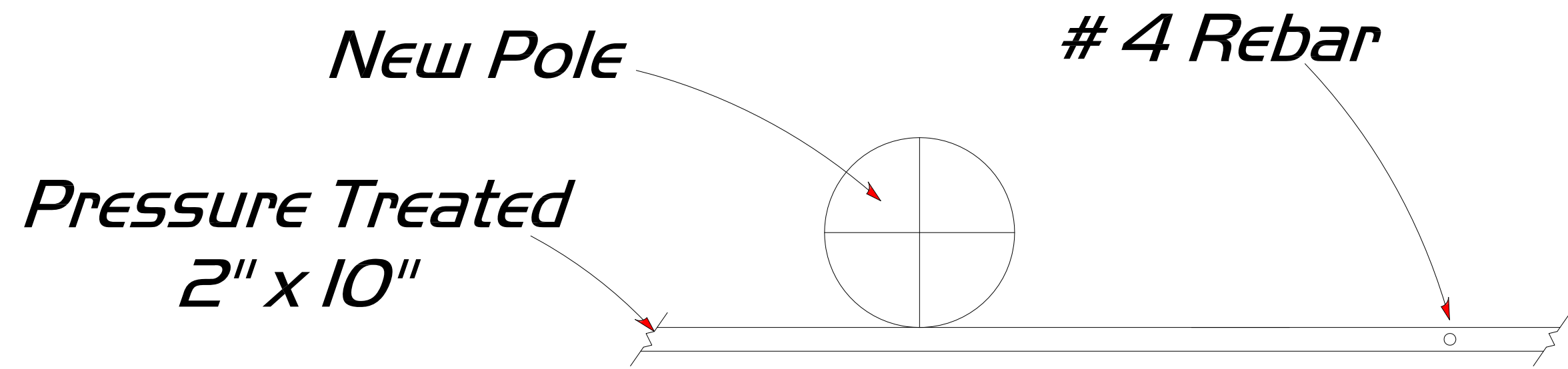
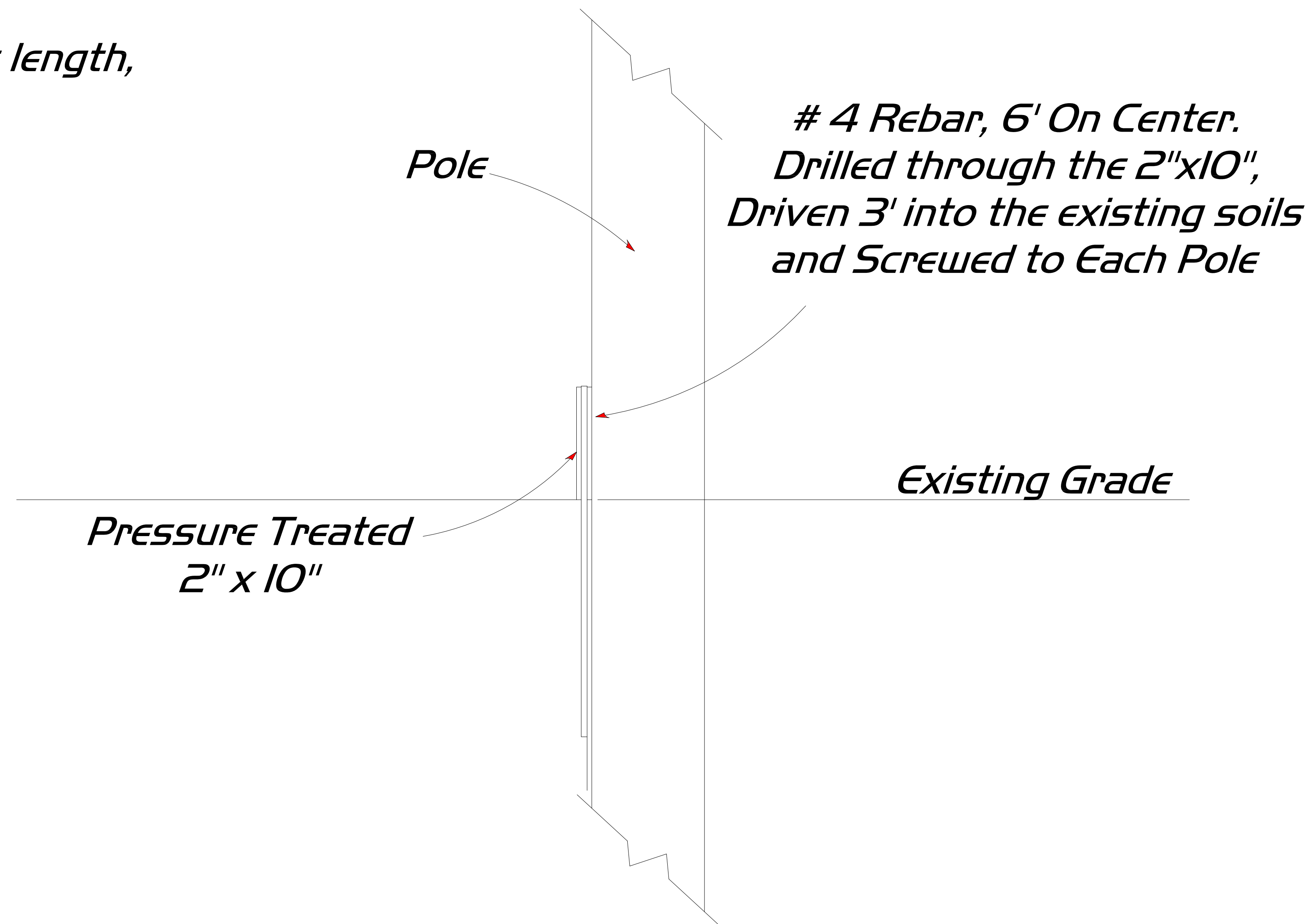

**PLAN VIEW**

**SECTION THROUGH  
at the BASE OF the POST**

NOTES:

> DO NOT SCALE DRAWING. NOT TO SCALE <

**RIDGEFIELD GOLF COURSE**

545 Ridgebury Road  
Ridgefield, Connecticut 06877

Replacement of Golf Netting Project

Submitted With Bid	
Client Comments	
Submitted to DOB for Review	
Submitted as Conformed	
Approved for Construction	
Client Comments	

**BALL STOP DETAIL (ALTERNATE #1)**

**RGC-03**

# TOWN OF RIDGEFIELD CONNECTICUT

## BOARD OF SELECTMEN

### INSTRUCTIONS TO BIDDERS

1. Bids will be submitted in a sealed envelope plainly marked with bid number to identify this particular proposal. The Town of Ridgefield will also accept electronic submission of bids via email. Bids submitted by email must be sent to [purchasing@ridgefieldct.gov](mailto:purchasing@ridgefieldct.gov). The time stamp of the hand delivery or email shall be on or before the bid due date. Only one method of submission is necessary.
2. Withdrawals of or amendments to bids received later than the time and date specified for bid opening will not be considered.
3. The Board of Selectmen of the Town of Ridgefield reserves the right to accept or reject any or all options, bids or proposals; to waive any technicality in any bid or part thereof, and to accept any bid deemed to be in the best interest of the Town of Ridgefield, Connecticut.
4. Bidders may be present at the opening of bids.
5. Bids may be held by the Town of Ridgefield for a period not to exceed sixty (60) days from the opening of bids for the purpose of reviewing the bids and investigating the qualifications of bidders prior to the awarding of the contract.
6. **Insurance requirements:** must be submitted with the bid. This includes any Hold Harmless requirements as well as Certificates of Insurance for the full amounts specified. **Unauthorized changes** to these forms, i.e. adding, striking out and/or changing any words, language or limits **will cause the bidder to be disqualified.**
  - a. **Please Note:** Prior to the start of work, the Town of Ridgefield and/or the Board of Education shall be endorsed on the Contractor's policies of insurance as additional insured. The Contractor shall obtain a policy of insurance, with minimum limits of liability as specified containing an endorsement that covers this agreement to indemnify, defend and hold harmless the Town/City and/or Board of Education or any of their officers, employees, agents, servants and volunteers. The Contractor shall obtain an

endorsement to said insurance policy stating that the Contractor's insurance is primary and any insurance obtained, or self insurance provided, by the Town of Ridgefield and/or Board of Education is excess. The Contractor's insurance carrier will waive all rights of subrogation against the Town of Ridgefield and/or Board of Education, and all of their respective officers, employees, agents, servants and volunteers. The Contractor shall furnish a copy of the insurance policy that meets all of the above requirements before any work or use of the property commences. Failure to do so will result in disqualification of the Bid. There will be no exceptions.

7. **Permits:** It is the Contractor's responsibility to obtain any necessary permits prior to the start of construction. All work shall be completed in compliance with the latest edition of the prevailing fire prevention and building codes in effect in the State of Connecticut, the latest edition of the State of Connecticut Department of Transportation Standard Specifications for Roads, Bridges and Incidental Construction, Town of Ridgefield Road Construction Standards, or as set forth in these specifications. Any local (Town of Ridgefield) permits will have the permit fee waived.
8. **Emergency Work:** The Contractor shall file with the Engineer a telephone number of a person authorized by him who may be contacted regarding emergency work at the job site that may be required during non-working hours for reasons of public safety. The person shall be readily available and have full authority to deal with any emergency that may occur.
9. **Sales Tax:** In accordance with the provisions of Special Act No. 77-98, as amended, and Section 12-412(a) of the Connecticut General Statutes, sales of tangible personal property and services to the Town are not subject to the Connecticut Sales and Use Tax, and such tax shall not be included as part of the bid.
10. **Contractor's Qualification Statement:** The Contractor's Qualification Statement must be filled out as part of the bid package and the experience and references listed therein will be one to the determining factors in the awarding of the bid.
11. **Hold Harmless Agreement:** In order for the bid to be considered valid, the Contractor **must** sign the enclosed hold harmless agreement. Bids submitted without the signed hold harmless agreement will be rejected.
12. **Prevailing Wage Rates:** This project **is not** subject to the State of Connecticut prevailing wage rate requirements.

**ESBE/MBE and Contract Compliance Requirements:** This project is not subject to State of Connecticut SBE/MBE Good Faith Effort and contract compliance requirements.

**Time of Completion:** Work will begin on 03/10/2025. All work must be completed by 05/01/2025. Contractor must ensure sufficient staffing and scheduling to complete the project within this time frame. No extensions will be granted unless approved in writing due to documented unforeseen conditions.

**Site Inspection:** Pre-bid site visit to familiarize themselves with the work site prior to bidding. Requests for site access shall be directed to Frank Sergiovanni, General Manager, via email [golfdirector@ridgefieldct.gov](mailto:golfdirector@ridgefieldct.gov). General bidding and technical questions shall be directed to David McFate, Purchasing and Finance Manager, via email [purchasing@ridgefieldct.gov](mailto:purchasing@ridgefieldct.gov).

**Bid Schedule:**

Pre-Bid Site Inspection –	Verify an appointment via email
RFI Requests Due -	Tue, 3/10/2025 by 4:00PM
RFI Responses Released-	Tue, 3/10/2025 by 4:00PM
Bid Due Date -	Tue, 3/11/2025 at 11:00AM

18. **Bid Submissions:** The following items shall be submitted for a bid to be considered complete. At the Town's discretion bidders may be given 24 hours to correct deficiencies in items (b)-(e).

- (a) Proposal on company letterhead
- (b) Insurance certificates
- (c) Hold Harmless Agreement
- (d) Contractor's Qualification Statement
- (e) Contractor's List of Subcontractors

19. **Requests for Information:** Questions or requests for information must be submitted in writing. All questions or requests for information shall be submitted to David McFate, Purchasing and Finance Manager, at [purchasing@ridgefieldct.gov](mailto:purchasing@ridgefieldct.gov). Deadline for Questions/RFI shall be May 6 NLT 4:00PM.

**HOLD HARMLESS AGREEMENT**

The undersigned covenants and agrees to and shall at all times indemnify, protect and save harmless the Town of Ridgefield from and against all costs or expenses resulting from any and all losses, damages, detriments, claims, demands, cost and charges including attorneys fees the Town of Ridgefield may directly or indirectly suffer, sustain or be subjected to by reason or on account of the work to be performed pursuant to this Contract or any activities in connection with said Contract whether such losses and damages be suffered or sustained by the Town of Ridgefield directly or by its employees, licenses or invitees or be suffered or sustained by other persons or corporations who may seek to hold the Town of Ridgefield liable therefore.

The Contractor shall comply with the Provisions of the Immigration Reform and Control Act of 1986 effective and enforceable as of June 6, 1987 which Act makes unlawful the hiring for employment or subcontracting individuals failing to provide documentation of legal eligibility to work in the United States. The Contractor shall hold the Town of Ridgefield harmless for the failure of the Contractor to comply with the provisions of said Act.

IN WITNESS WHEREOF, the parties hereto have set their hand and seal this on the \_\_\_\_\_ day of \_\_\_\_\_

Signed, Sealed and Delivered in the  
Presence of:

Signed:

\_\_\_\_\_  
Notary Public

\_\_\_\_\_

**CONTRACTOR’S QUALIFICATION STATEMENT**

List below references for similar projects, including all information requested. This page must be completed and submitted with the bid.

1. Client: \_\_\_\_\_

Project Address: \_\_\_\_\_

Approximate Value: \_\_\_\_\_ Date: Started \_\_\_\_\_ Completed \_\_\_\_\_

Contact: Name \_\_\_\_\_ Telephone \_\_\_\_\_

2. Client: \_\_\_\_\_

Project Address: \_\_\_\_\_

Approximate Value: \_\_\_\_\_ Date: Started \_\_\_\_\_ Completed \_\_\_\_\_

Contact: Name \_\_\_\_\_ Telephone \_\_\_\_\_

3. Client: \_\_\_\_\_

Project Address: \_\_\_\_\_

Approximate Value: \_\_\_\_\_ Date: Started \_\_\_\_\_ Completed \_\_\_\_\_

Contact: Name \_\_\_\_\_ Telephone \_\_\_\_\_

4. Client: \_\_\_\_\_

Project Address: \_\_\_\_\_

Approximate Value: \_\_\_\_\_ Date: Started \_\_\_\_\_ Completed \_\_\_\_\_

Contact: Name \_\_\_\_\_ Telephone \_\_\_\_\_

*Company:* \_\_\_\_\_ *Bid Title:* \_\_\_\_\_

*Street:* \_\_\_\_\_ *Bid No.:* \_\_\_\_\_

*City, State:* \_\_\_\_\_ *Telephone No.:* \_\_\_\_\_

